

AEV250 Series DC Contactor Specification 400 Amp / 900 VDC



Application

AEV250 Series is used for charging (pile) station, battery power supply, DC power control, circuit protection and other electric vehicle power switch controls. Also it could be widely used in uninterruptible power supply and other electronic control systems.

Features

HIGH CURRENT AND HIGH VOLTAGE

Contact chamber is filed with inert gas to minimize arcing, up to 900VDC load is available.

COMPACT STRUCTURE, LOW NOISE

Contact design yields reduced unit size, low noise while carrying or switching currents.

COIL ECONOMIZER

Built-in coil economizer – only 1.7W hold power @12VDC and it limits back EMF to 0V.

HIGH SAFETY

There is no arc leakage due to tight sealing.

HIGH RELIABLE CONTACT

Stable contact resistance no matter how harsh environment with sealed contacts.

NO SPECIAL REQUIREMENT FOR MOUNTING

Light weight actuator is less impacted by gravity with no special mounting orientation requirements.

VARIOUS APPLICATION

Application includes battery switch and standby equipment, DC power control, circuit protection, etc.

COMPLY WITH EU ROHS DIRECTIVE (2011/65/EU)

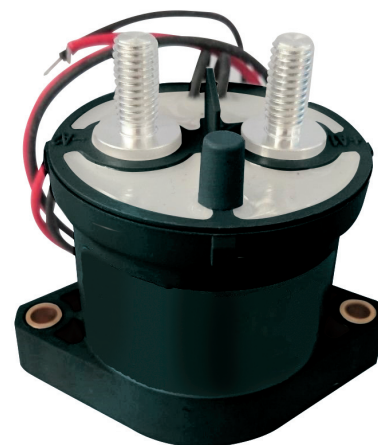

Nomenclature

Example AEV250 – M AN

Series code:

“AEV250” = AEV250 Series

Coil Voltage Code::

“M” = 12 - 24 VDC

“F” = 72 VDC

“G” = 48 - 72 VDC

Options (applied in this order):

Blank = Std. Options (Bottom Mount, Without Aux. Contact & Polarized Load Terminals)

“A” = With Aux. Contact (SPST-NO)

“B” = With Aux. Contact (SPST-NC)

“N” = Non-Polar Load Terminals

“P” = Potted PCB

“E” = Without Coil Economizer (External Coil Economizer Required, not UL approved)

AEV250 Series DC Contactor Specification 400 Amp / 900 VDC

Performance Data

MAIN CONTACT		LIFE	
Contact arrangement	1 Form X (SPST-NO DM)	Resistive load life	See chart below
Rated Operating Voltage	12-900VDC	Mechanical life	200,000 cycles
Continuous (Carry) Current	250A ²	AUX. CONTACT	
Max short circuit current	3,000A, 1 sec. ¹	Aux. Contact arrangement	1 Form A, 1 Form B
Max Breaking Unit	2,000A@450VDC, 1 cycle		
Dielectric Withstanding Voltage (Initial)	Between open contacts: 4,000 VDC, ≤1mA, 1min. Between contact and coil: 2,200 Vrms, ≤1mA, 1 min.	Aux. Contact Current Max	2A@30VDC/ 3A@125VAC
Insulation Resistance	Terminal to Terminal/ Terminal to coil Min 1000 MΩ@1000Vdc	Aux. Contact Current Min	100mA@8V
Voltage Drop (Initial)	Max. 125mV (250A)	Aux. Contact Resistance Max	0.417ohms@30VDC/ 0.150ohms @125VAC
ENVIRONMENTAL DATA		OPERATE / RELEASE TIME	
Shock,11ms ½ sine, operating	20G Peak	Close (includes bounce)	25ms, Max.@20°C
Vibration, Sine, Peak, 20G	80 to 2,000Hz	Release (@2000A includes arc)	12ms, Max.@20°C
Operating Ambient Temperature	-40 to +85°C		
Altitude	<4000m		
Weight	0.95 Lb (0.43 kg)		
COIL DATA	M Coil	F Coil	G Coil
Coil Voltage	12 - 24VDC	72VDC	48 - 72VDC
Voltage (Max.)	36VDC	95VDC	95VDC
Pickup voltage (Max.)	9VDC	48VDC	32VDC
Dropout voltage (Min.)	6VDC	27VDC	18VDC
Inrush Current (Max.)	3.8A	0.7A	1.3A
Holding Current (Avg.)	0.13A@12VDC / 0.07A@24VDC	0.02A@72VDC	0.03A@48VDC

Note:

*1: Does not meet dielectric & IR after test.

*2: Higher currents are possible, based on cross-sectional area of the conductor. Example, 500A @ 65°C, 400MCM conductor.

AEV250 Series DC Contactor Specification 400 Amp / 900 VDC

Electrical life

Estimated Make & Break Resistive Load Ratings for polarized type

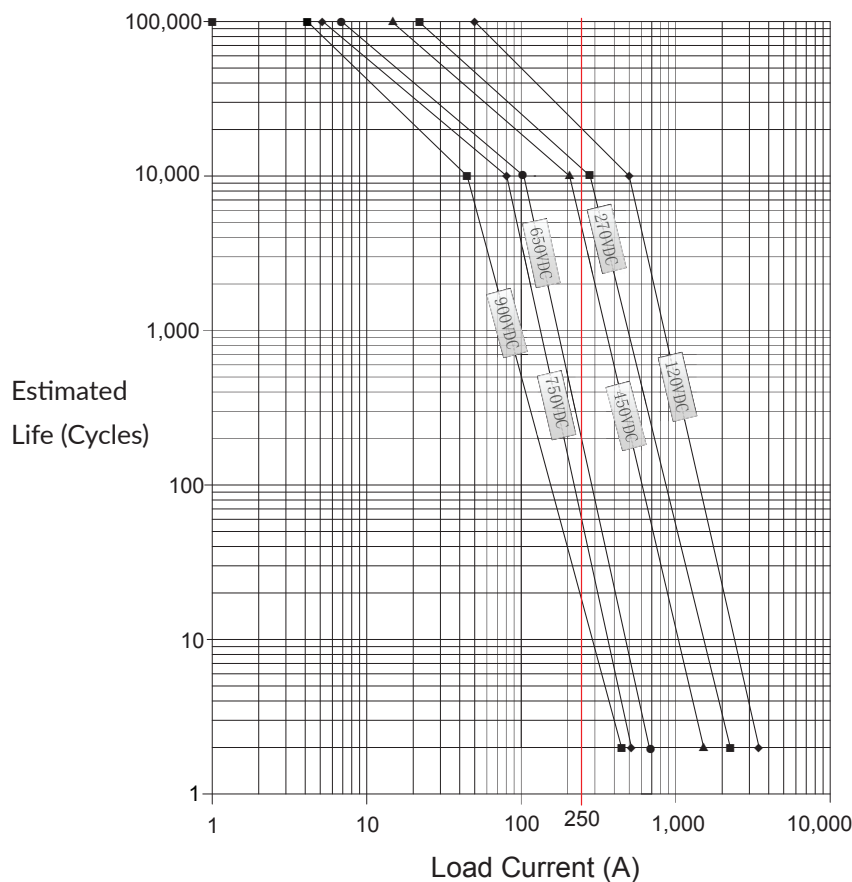

Note:

Estimates based on extrapolated data. User is encouraged to confirm performance in application.

Estimated Electrical Life: Polarity Sensitive Type

Voltage (V)	450	650
Current (A)	250	250
Life (Cycle)	5000	200

Estimated Electrical Life: Non-Polarity Sensitive Type

Voltage (V)	450	650
Current (A)	250	250
Life (Cycle)	2000	100

AEV250 Series DC Contactor Specification 400 Amp / 900 VDC

AEV250 Carry Current Performance

Carry Current vs Time (85°C)
(Copper Conductor 60mm²)

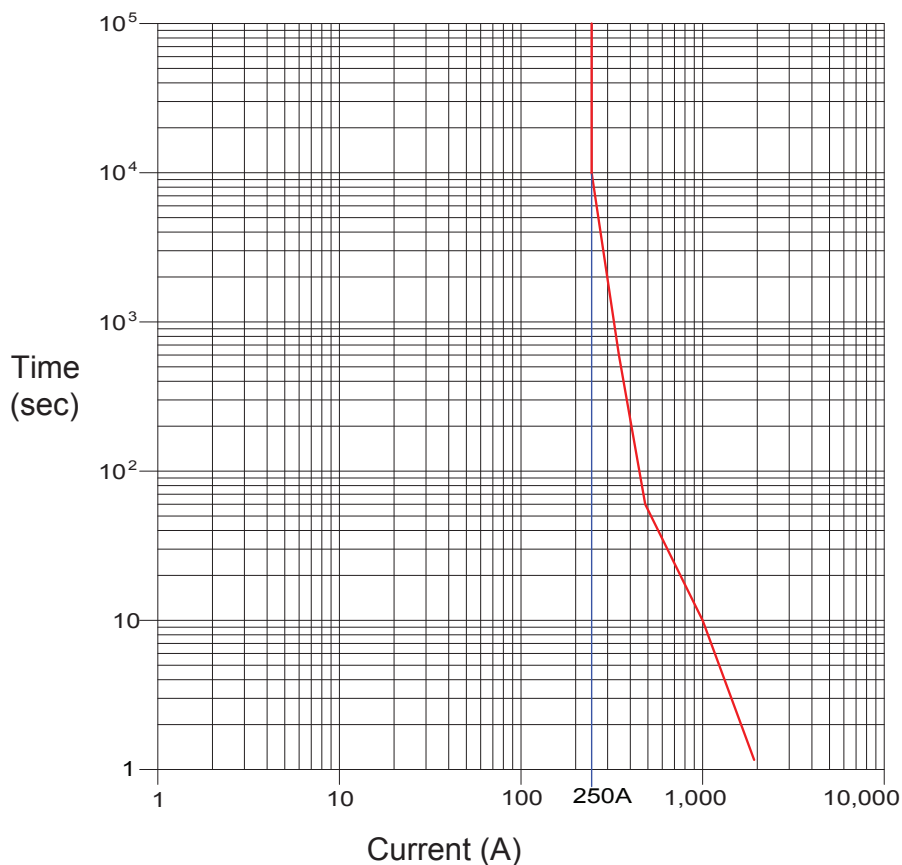

Outline Dimensions: in. (mm)

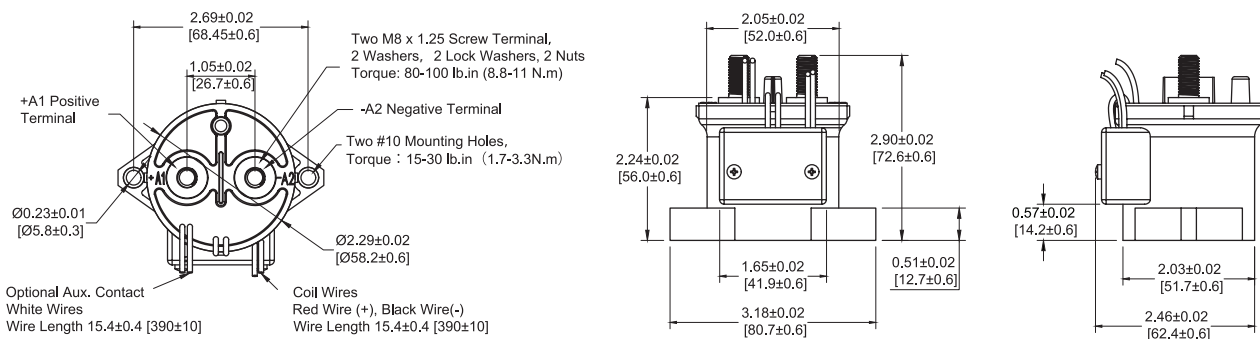

Note:

There is a "+A1" & "-A2" mark on the cover of polar products, no mark for the bi-directional (non-polar) ones.

AEV250 Series DC Contactor Specification 400 Amp / 900 VDC

Application Note:

1. To prevent loosening, washers should be used whenever the contactor is installed. All terminals or copper bar must be in direct contact with the contactor's main terminals. Please control the screw tightening torque of each part within the specified range in the table below. If the torque exceeds the recommended range, it may cause damage to the sealed cavity and thread damage.

- Contact torque (M8): 80 - 100 lb.in (8.8 - 11 N.m)
- Mounting torque: 15 - 30 lb.in (1.7 - 3.3 N.m) Max.

2. Products with a coil economizer are already equipped with back EMF circuits, so there is no need to use surge protectors.

3. Avoid installing the contactor in a strong magnetic field environment (near transformers or magnets) and avoid placing the contactor near objects with heat radiation.

4. When continuous current is applied to the contacts of the relay, and the Coil is turned on immediately after the power is cut off. At this time, as the temperature of the coil increases, the resistance of the coil will also increase, which will increase the pull-in voltage of the product, which may result in exceeding the rated Pull-in voltage. In this case, the following measures should be taken to reduce the load current; limit the continuous power-on time or use a coil voltage higher than the rated pull-in voltage.

5. When voltage is applied to products with a coil economizer, the circuit will automatically switch to the holding voltage about 100ms later. Please do not repeat the on-off operation during this time period, or the coil economizer of the contactor may be damaged.

6. When the voltage applied to the coil exceeds the maximum allowable applied voltage, the coil temperature may rise and lead to coil damage and inter-layer short circuit.

7. The rated values in the contact parameters are values for a resistive load. When using an inductive load with $L/R > 1\text{ms}$, please connect a surge current protection device to the inductive load in parallel. If no measures are taken, the electrical life may be reduced, and the continuity may be poor. Please consider sufficient margin space in the design.

8. Supply power must be greater than coil power or it will reduce performance capability.

9. Please do not allow debris and oil to adhere to the main terminals; Make sure that the main terminals are in reliable contact with the load conductor, otherwise the temperature rise of the terminal / conductor connection may be too high due to the excessive contact resistance.

10. The load conductor must have the corresponding current load capacity and heat dissipation capacity (it is recommended to use a copper bar with min 50mm²), to prevent overheating and affecting the life of the contactor.

11. Do not use if dropped.

12. Is impossible to determine all the performance parameters of contactors in each specific application, therefore, customers should choose the products matching them according to their own conditions of use. If in doubt, contact Altran, however, the customer will be responsible for validating that the products meet their application.

13. Altran reserves the right to make changes as needed. Customers should reconfirm the contents of the specification or ask for us to supply a new specification if necessary.